

SilverPlus is a proven technology that dramatically extends electrode life and significantly reduces operating cost. This remarkable technological advance is now available on our current HT4001 water injection plasma system; our discontinued HT4000 and HT400 systems will also benefit from this electrode.



HT4001[®] SilverPlus[™] Quick Set-up



To achieve maximum SilverPlus electrode life

A fully used SilverPlus electrode will have a pit depth of .080" (2 mm). Note: This is deeper than the recommended .040" (1 mm) pit depth for standard parts.

Purge torch: after each parts change purge the torch for at least 30 seconds to remove residual moisture. Moisture will cause damage to the silver electrode.

Adjust gas flows: Plasma gas flow rate is critical. High flow will cause rapid electrode wear and hard starting. Low flow will cause uncontrolled arcing. (See charts below.)

Adjust arc voltage: As the electrode wears, the torch will get closer to the plate. To compensate for this, increase arc voltage in 5-volt increments, up to 15 volts higher than the initial setting.

Avoid ramp-down errors: Ramp down errors can occur when rip cutting off the plate or when leading out to the dropped part as the arc stretches. These "blowouts" shorten electrode life by 10 or more starts per occurrence.

If used on an HT400, this is not an issue, as the HT400 was not equipped with LongLife[®] ramping technology.

| Part number | Description | Systems |
|-------------|------------------------------|-----------------------|
| 1. | 220397 Electrode, SilverPlus | HT4001, HT4000, HT400 |
| 2. | 020623 Swirl ring (cw) | HT4001, HT4000 |
| 3. | 120015 Swirl ring (ccw) | HT4001, HT4000 |
| 4. | 020096 Swirl ring (cw) | HT400 |
| 5. | 020086 Nozzle (cw) | HT4001, HT4000, HT400 |
| 6. | 020392 Nozzle (ccw) | HT4001, HT4000 |
| 7. | 020579 Retaining cap | HT4001, HT4000, HT400 |
| 8. | 120465 Retaining cap - CE | HT4001 |

To achieve maximum nozzle life

With careful use, the standard 260-amp nozzle will last 1:1 with the new SilverPlus electrode.

Pierce at correct height:

Piercing too low causes molten metal (spatter) to build up on the nozzle ceramic causing damage to ceramic and copper nozzle orifice. This is the most common cause of premature nozzle failure. Piercing too high can cause slow arc transfer and misfires. In most applications 3/8 – 1/2" (10 – 13 mm) pierce height works well.

Adjust gas and cut water flows: Cut water and preflow gas protect the nozzle from damage especially during piercing. Make sure cut water flow and preflow settings are adjusted according to the cut chart.

Adjust arc voltage: As parts wear, adjust arc voltage up in 5-volt increments to keep the nozzle from dragging on the plate. Damage to the nozzle ceramic may occur if the torch contacts the plate during cutting.



HT4001, 260-amp cut chart

| Material thickness | | Test preflow rate | | Test cut flow rate | Water flow setting | Arc volts | Arc current | Torch standoff | | Travel speed | |
|--------------------|------|-----------------------|-----------------------|-----------------------|--------------------|-----------|-------------|----------------|------|--------------|----------|
| (in) | (mm) | (N ₂) (%) | (O ₂) (%) | (O ₂) (%) | (%) | (V) | (A) | (in) | (mm) | (ipm) | (mm/min) |
| 1/4 | 6,35 | 16 | 11 | 80 | 60 | 120 | 260 | 1/8 | 3 | 170 | 4320 |
| 1/2 | 12,7 | 16 | 11 | 80 | 60 | 130 | 260 | 3/16 | 5 | 100 | 2540 |
| 3/4 | 19,1 | 16 | 11 | 80 | 60 | 135 | 260 | 3/16 | 5 | 70 | 1780 |
| 1 | 25,4 | 16 | 11 | 80 | 60 | 140 | 260 | 3/16 | 5 | 50 | 1270 |

HT4000, 260-amp cut chart

| Material thickness | | Test preflow rate | | Test cut flow rate | Water flow setting | Arc volts | Arc current | Torch standoff | | Travel speed | |
|--------------------|------|-----------------------|-----------------------|-----------------------|--------------------|-----------|-------------|----------------|------|--------------|----------|
| (in) | (mm) | (N ₂) (%) | (O ₂) (%) | (O ₂) (%) | (%) | (V) | (A) | (in) | (mm) | (ipm) | (mm/min) |
| 1/4 | 6 | 17 | 10 | 80 | 100 | 120 | 260 | 1/8 | 3 | 170 | 4318 |
| 1/2 | 13 | 17 | 10 | 80 | 100 | 130 | 260 | 3/16 | 5 | 100 | 2540 |
| 3/4 | 19 | 17 | 10 | 80 | 100 | 135 | 260 | 3/16 | 5 | 70 | 1778 |
| 1 | 25 | 17 | 10 | 80 | 100 | 140 | 260 | 3/16 | 5 | 50 | 1270 |

HT400, 260-amp cut chart

| Material thickness | | Test cut flow rate | Water flow setting | Arc volts | Arc current | Torch standoff | | Travel speed | |
|--------------------|------|-----------------------|--------------------|-----------|-------------|----------------|------|--------------|----------|
| (in) | (mm) | (O ₂) (%) | (%) | (V) | (A) | (in) | (mm) | (ipm) | (mm/min) |
| 1/4 | 6 | 36 | 100 | 120 | 260 | 1/8 | 3 | 170 | 4318 |
| 1/2 | 13 | 36 | 100 | 130 | 260 | 3/16 | 5 | 100 | 2540 |
| 3/4 | 19 | 36 | 100 | 135 | 260 | 3/16 | 5 | 70 | 1778 |
| 1 | 25 | 36 | 100 | 140 | 260 | 3/16 | 5 | 50 | 1270 |

Half-used electrode

Whereas a standard copper electrode would be fully used, this SilverPlus electrode is only half consumed. The pit in the center of the part measures .040" (1 mm). Electrodes are often removed prematurely due to cut quality deterioration caused by nozzle damage. A new nozzle will restore cut quality and allow full electrode use.

Fully-used electrode

This SilverPlus electrode has provided full use. The pit depth is .080" (2 mm). The operator increased the arc voltage by 15 volts from the first cuts made with this electrode to the last. This maintains a constant distance between the torch and the work piece through the life of the electrode.

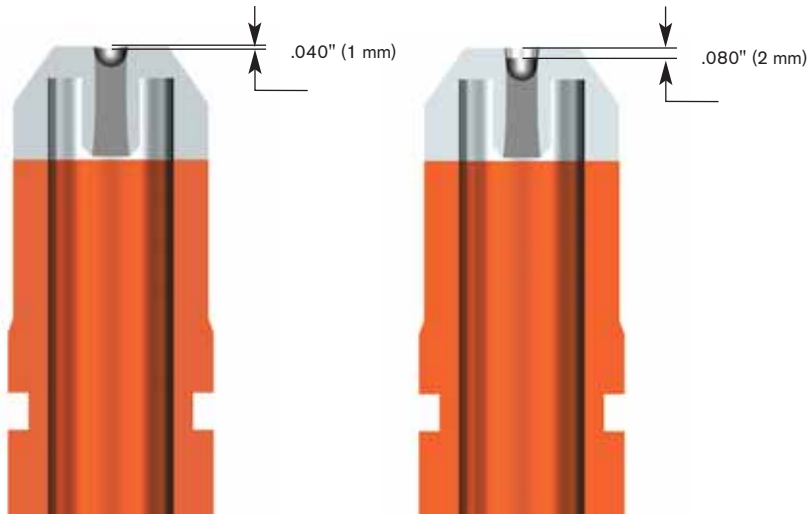

260-amp HT400 oxygen electrode life

Field test results

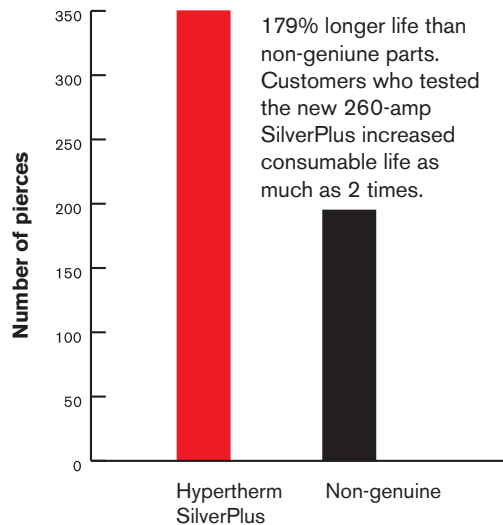

Hypertherm®

Hypertherm, Inc.
Hanover, NH 03755 USA
603-643-3441 Tel

Hypertherm Europe B.V.
4704 SE Roosendaal, Nederland
31 165 596907 Tel

Hypertherm (Shanghai) Trading Co., Ltd.
PR China 200052
86-21 5258 3330 /1 Tel

Hypertherm (S) Pte Ltd.
Singapore 349567
65 6 841 2489 Tel

Hypertherm (India) Thermal Cutting Pvt. Ltd.
Chennai, Tamil Nadu
91 0 44 2834 5361 Tel

Hypertherm Brasil Ltda.
Guarulhos, SP - Brasil
55 11 2409 2636 Tel

Hypertherm México, S.A. de C.V.
México, D.F.
52 55 5681 8109 Tel

www.hypertherm.com

Hypertherm, HT and SilverPlus are trademarks of Hypertherm, Inc., and may be registered in the United States and/or other countries.

© 10/04 Hypertherm, Inc. Revision 0

891680